

50kgN 절연이음매침목 레일체결장치

체결부 상세 S=1:2

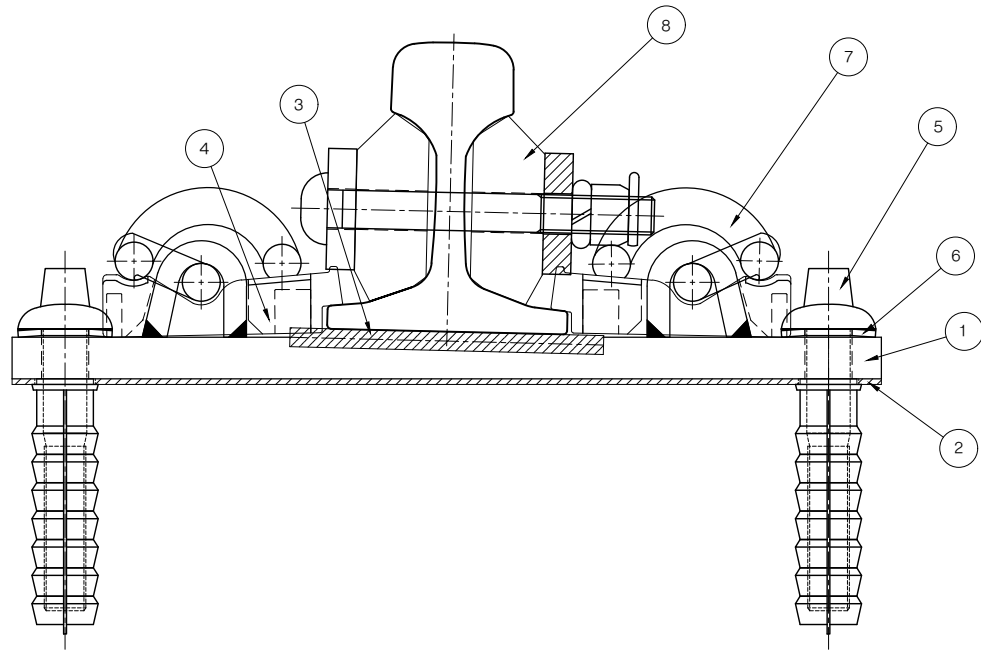

평면도 S=1:10

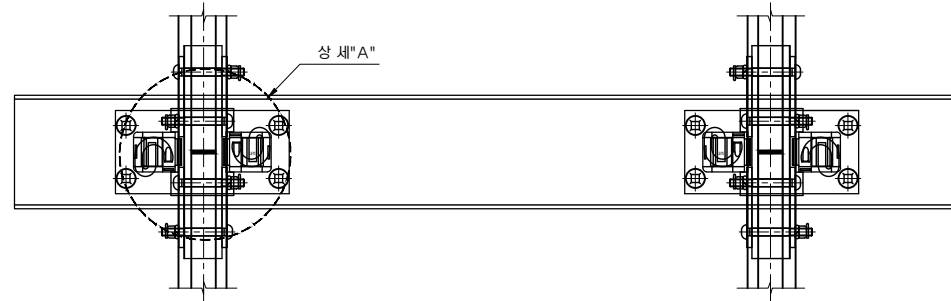

나사스파이크 S=1:2

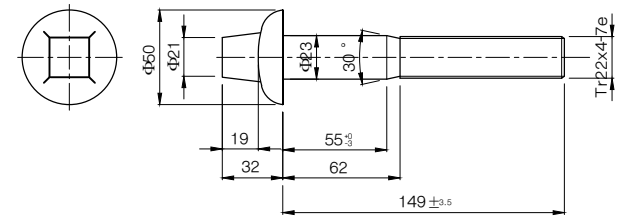

단면도 S=1:10

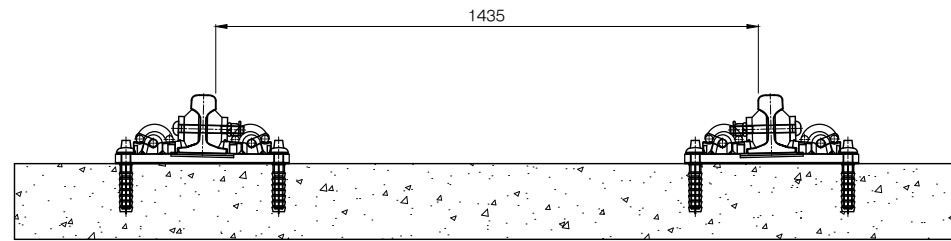

레일 패드 S=1:2

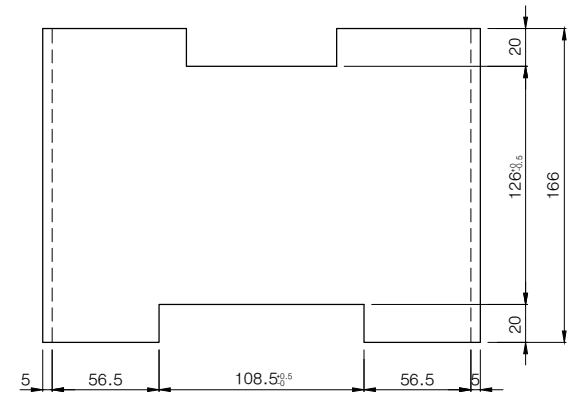

베이스플레이트 S=1:5

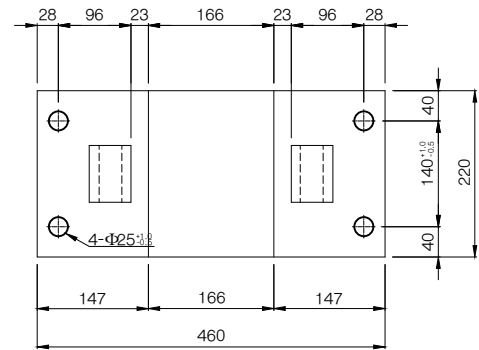

베이스플레이트패드 S=1:5

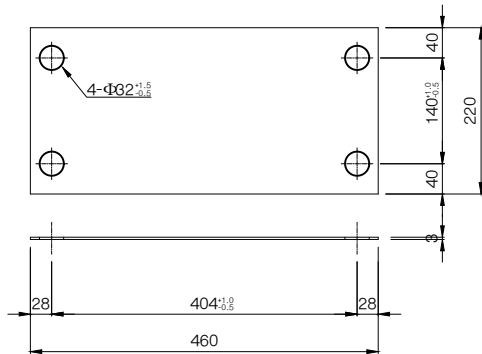

절연 블럭 S=1:2

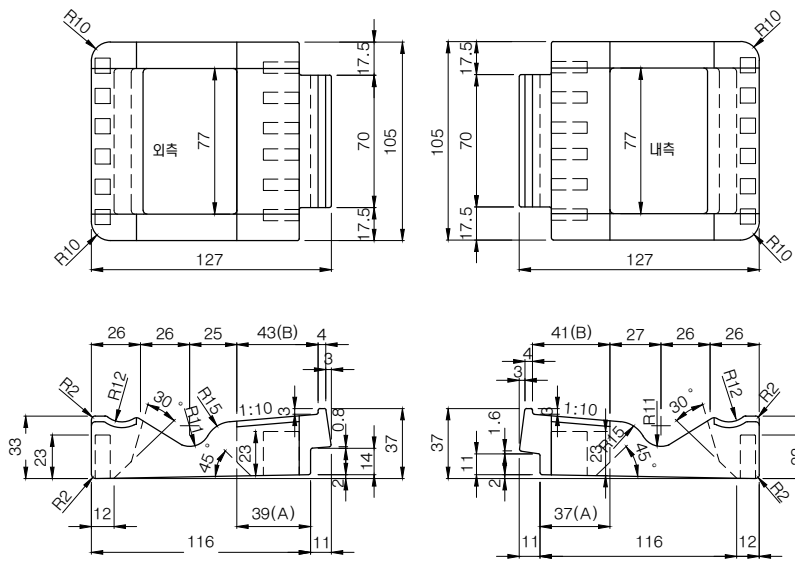

접시 스프링 와샤 S=1:1

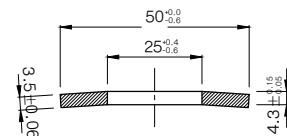

재료표

품번	품명	규격	재질	수량	비고
1	베이스플레이트	22t×220×460	SS 400	개 2	
2	베이스플레이트패드	3t×220×460	E.P.D.M	개 2	
3	레일패드	5t×166×231.5	EVA or TPU	개 2	
4	절연블럭	D.W.G	NYLON66 + GF	개 4	
5	나사스파이크	Ø22×149	SCM 440	개 8	
6	접시 스프링와셔	50 CRV4	HSWR	개 8	
7	코일스프링 크립	PC 침목용	SPS4	개 4	
8	절연이음매판	50kg N 용	FRP	개 2	공급품목제외